

Specialty Cooking Equipment



Tempura Wok Range
Model ISP-18-W



Mandarin Wok Range
Model ISP-J-W-13



Hi-Temp Stock Pot Ranges
Model ISP-J-SP

Features

- Stainless steel front, sides and cabinet.
- Welded stainless steel seams.
- Heavy duty legs with adjustable feet.
6" (152) standard on ISP-18W.
12" (305) standard on ISP-J-W-13 and ISP-J-SP.
- One year parts and labor warranty.
- AGA and CGA design certified, NSF listed.



Model Numbers

Tempura Wok Range

- ISP-18W

Mandarin Wok Range

- ISP-J-W-13

Hi-Temp Stock Pot Ranges

- ISP-J-SP

Tempura Wok Range Features

- 3-Ring burner with two adjustable gas valves provide flexibility and maximum 90,000 BTU/hr. (26 kw) high performance cooking. Heat selections from simmer to high heat.
- Burners are equipped with two continuous pilots for instant ignition.
- Heavy duty cast iron wok removes for cleaning.
- 16" (406) wok opening holds an 18" (457) wok.
- Roll front is easy to load and gradual slope design reduces spill-overs.
- Sturdy stainless steel cabinet base provides additional storage.

Mandarin Wok Range Features

- Anti-clogging 125,000 BTU/hr. (37 KW) 18-Tip Jet Burner with cone-shaped intense heat.
- Burners are equipped with two continuous pilots for instant ignition.
- Wok top is all welded 12 gauge steel. Removes for cleaning.
- Model ISP-J-W-13 has a 13" (330) wok opening to hold a 14" (356) wok. Model ISP-J-W-16 has a 16" (406) wok opening for an 18" (457) wok.
- Roll front is easy to load and gradual slope design reduces spill-overs.
- Sturdy stainless steel cabinet base provides additional storage.

Stock Pot Range Features

- Anti-clogging 18-Tip Jet Burner with cone-shaped intense heat. 125,000 BTU/hr. (37).
- Burners are equipped with two continuous pilots for instant ignition.
- Heavy duty cast iron top grate removes for cleaning.
- Roll front is easy to load and gradual slope design reduces spill-overs.
- Sturdy stainless steel cabinet base provides additional storage.

All measurements in () are metric equivalents.

Imperial Commercial Cooking Equipment

1128 Sherborn Street ■ Corona, CA 92879 ■ 800.343.7790 ■ Ph: 951.281.1830 ■ Fx: 951.281.1879

www.imperialrange.com ■ E-mail: imperialsales@imperialrange.com

Imperial Specialty Cooking Equipment

Specification #:

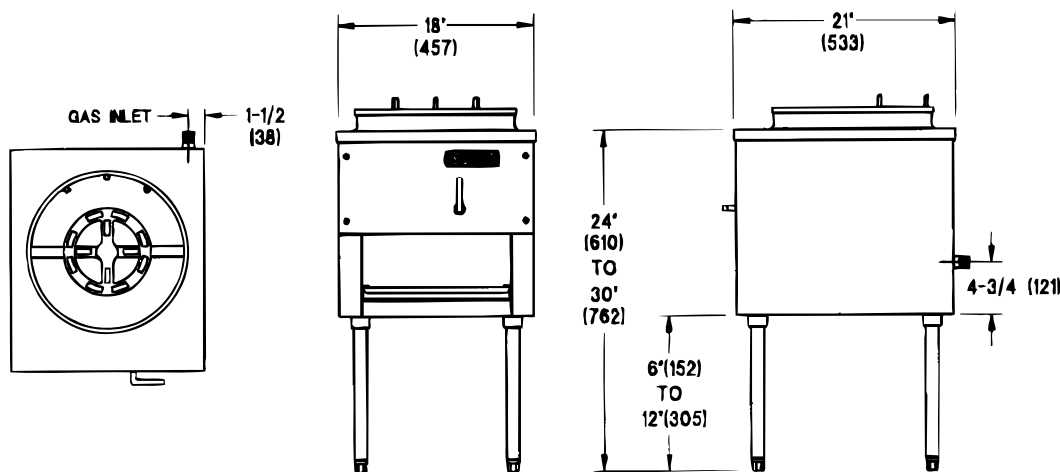

Model#	Width	Depth	Height	Top Opening	Burner Description	Gas Output BTU	(KW)	Ship Weight (Kg.)	Lbs.
Tempura Wok Range									
ISP-18-W	18" (457)	21" (533)	30" (533)	16" (406)	3-Ring Burner	90,000	(26)	(57)	125
Mandarin Wok Range									
ISP-J-W-13	18" (457)	21" (533)	30" (533)	13" (330)	Anti-clogging Jet Burner	125,000	(37)	(59)	130
ISP-J-W-16	18" (457)	21" (533)	30" (533)	16" (406)	Anti-clogging Jet Burner	125,000	(37)	(57)	125

Crated Dimensions: Height = 28" (712) Depth: add 2 1/2" (64) to unit depth. Width: add 2 1/2" (64) to unit width. All measurements in () are metric equivalents.

Standard Exterior Specifications

Front, sides and cabinet base shall be constructed of stainless steel with welded and finished stainless steel seams. Set of four, 6" (152) adjustable legs shall be standard for ISPA-18 and ISPA-18-2. Set of four, 12" (305) adjustable legs shall be standard for ISP-J-SP and ISP-J-SP-2. Control knobs shall be durable cast iron with a polished chrome finish. Full width drip pan shall remove for cleaning.

Burner Specifications

3-Ring burner's inner ring shall provide 45,000 BTU/hr. (13 KW) and outer ring shall provide an additional 45,000 BTU/hr. (13 KW). Heavy duty burner shall weigh 32 lbs. (15 Kg). Wok top shall be made of all-welded 12 gauge steel.

Mandarin wok burner shall be anti-clogging jet burner type rated at 125,000 BTU/hr. (37 KW) providing cone shaped intense heat. Knee-level "L" shaped handle shall adjust gas keeping hands free for cooking.

Intense heat stock pot shall be anti-clogging jet burner type rated at 125,000 BTU/hr. (37 KW) providing cone shaped intense heat. Top Grate shall be heavy duty casting weighing 38 lbs. (17 Kg) and shall be designed with a gradual slope to reduce spillovers. Burners shall be equipped with two adjustable gas valves and two continuous pilots for instant ignition.

Gas: Manifold pressure is 5.0" W.C. for natural gas or 10.0" for propane gas. Manifold size 3/4"(19) NPT. 3/4" (19) pressure regulator supplied with equipment to be installed at time of connection. Specify type of gas and elevation if over 2000 ft. (610 m).

Clearance: For use only on non-combustible floors. Legs or casters are required for non-combustible floors. Provide 0" clearance from non-combustible surfaces and 17" (432) from combustible surfaces.

Optional Items

- Custom heights
- Custom wok openings
- Stainless steel tops
- Quick disconnect and flexible gas hose
- Extra burner control for 3-Ring Burner
- Extra top grate
- Side-by-side models available for ISP-J-SP
- 6" (152) casters

Interchangeable Tops (no tools required)

- ISP-18W may be interchanged with ISPA-18 Stock Pot (on separate specification sheet Stock Pot Range C-4)
- ISP-J-W-13 may be interchanged with ISP-J-SP



3-Ring Burner. Standard burner with two adjustable valves.



Anti-clogging 18-Tip Jet Burner

AIA File #:

Imperial Commercial Cooking Equipment

1128 Sherborn Street ■ Corona, CA 92879 ■ 800.343.7790 ■ Ph: 951.281.1830 ■ Fx: 951.281.1879

www.imperialrange.com ■ E-mail: imperialsales@imperialrange.com