

**REFRIGERATOR MANUFACTURER**  
**Turbo air**  
 more durable, convenient, beautiful

1250 Victoria St  
 Carson, CA 90746  
 Tel. 310-900-1000  
 Fax. 310-900-1077  
 www.turboairinc.com

Project :	
Model # :	
Item # :	Qty :
Available W/H :	
Approval :	

## Beer Dispensers

Underbar Equipment  
 Beer Dispensers

**EXCEPTIONAL 3 YEAR  
 PARTS & LABOR WARRANTY**

**Model : TBD-2SD/SB**



**TBD-2SD**



**TBD-2SB**

- Does not include keg couplers
- 2 Year Parts and Labor Warranty for SB Unit

### FEATURES / BENEFITS

- EFFICIENT REFRIGERATION SYSTEM**  
 Turbo Air's refrigerators are designed with oversized and balanced R-134A (CFC Free) refrigeration systems. These include efficient evaporators and condensers for faster cooling and greater efficiency.
- FORCED AIR COOLING SYSTEM**  
 Fast cooling and balanced temperature throughout the cabinet.
- STAINLESS STEEL CABINET CONSTRUCTION**  
 Super Deluxe (SD) models boast a stainless steel exterior (except galvanized steel back and bottom). SB models are attractive wear-resistant black vinyl exterior. Heavy gauge stainless steel countertop is perfect for sanitation and durability. Interior is stainless steel floor and door liners with white painted galvanized steel inside walls. Turbo Air Beer Dispenser model guarantees utmost in cleanliness and long product life. It also can add a touch of style to the most refined setting.
- HIGH-DENSITY POLYURETHANE INSULATION**  
 The entire cabinet structure is foamed-in-place using high density, CFC free polyurethane insulation.
- 3" DIAMETER STAINLESS STEEL INSULATED BEER COLUMNS**
- ERGONOMICALLY DESIGNED DOORS**  
 Customers' fatigue fades away with easy grip handles and doors that open effortlessly. These features along with self-closing doors make this the ultimate choice in customer convenience.
- SIDE MOUNT COMPRESSOR UNIT**  
 Through positioning the compressor to the side, the refrigerator can be serviced without being moved. By innovatively creating a **front breathing** feature, this model can provide high efficiency in narrow spaces.
- INCANDESCENT INTERIOR LIGHTING**
- REFRIGERATOR HOLDS 33°F ~ 38°F FOR THE BEST IN BEVERAGE PRESERVATION**

‡ ENERGY STAR rated models



Model	Swing Door	1/2 Barrels	HP	AMPS	Crated Weight (lbs.)	L x D* x H† (inches)
<b>TBD-2SD ‡</b>	<b>2</b>	<b>2</b>	<b>1/3</b>	<b>7</b>	<b>303</b>	<b>58 3/4 x 27 1/8 x 37</b>
<b>TBD-2SB</b>	<b>2</b>	<b>2</b>	<b>1/3</b>	<b>7</b>	<b>313</b>	<b>58 3/4 x 27 1/8 x 37</b>

## Model : TBD-2SD/SB

ELECTRICAL DATA	
Voltage	115/60/1
Plug Type	 NEMA-5-15P
Full Load Amperes	7
Compressor HP	1/3
Refrigerant	R-134A
Cord Length (ft.)	9
Lamp (w)	25W
DIMENSIONAL DATA	
Cubic feet (1/2 Barrels)	2
Ext. Length Overall in.	58 <sup>3</sup> / <sub>4</sub> (1492mm)
Ext. Depth Overall in.*	27 <sup>1</sup> / <sub>8</sub> (691mm)
Ext. Height Overall in.†	37 (940mm)
Gross Weight lbs.	303 / 313
Net Weight lbs.	276 / 286
# of Swing Door	2

Design and specifications subject to change without notice.  
Actual shipping weight may differ due to extra packing materials for product protection.  
\* Depth does not include 2" for rear spacers.  
† Height does not include 5" for caster height. Height does not include 15-1/8" for draft arm.

- **WARRANTY :** 3 Year Parts and Labor Warranty  
(SD Model) Additional 2 Year Warranty on Compressor
- **WARRANTY :** 2 Year Parts and Labor Warranty  
(SB Model) Additional 3 Year Warranty on Compressor
- SELF-CONTAINED SYSTEM
- 4" SWIVEL CASTERS STANDARD
- 2 FAUCETS BEER COLUMNS AVAILABLE (OPTIONAL)
- DOOR LOCKS STANDARD

## PLAN VIEW

(unit : inch)

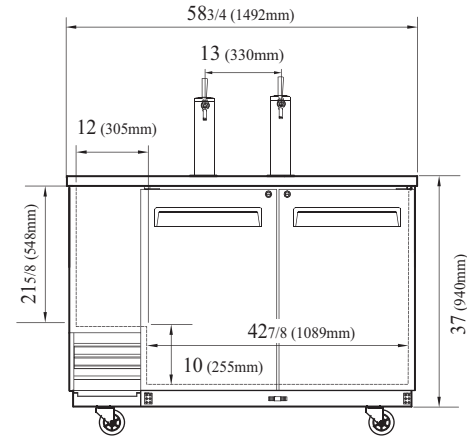

FRONT VIEW

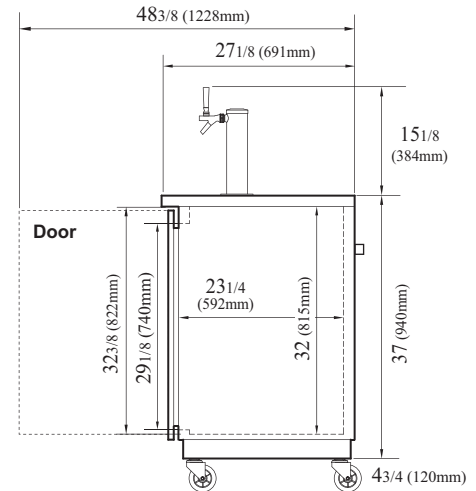

SIDE VIEW

Ver.201301

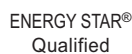

- Turbo Air : 800-627-0032
- GK : 800-500-3519
- Warranty : 800-381-7770
- AC : 888-900-1002

